

*** PATENT PENDING**

SPECIFICATIONS

Material: Silicone rubber conforms to A-A-59588, Class III, GR25 (unless otherwise specified).
Mounting Nut: Brass, black oxide
Temperature Range: -94° F to +400° F (-70° C to +204° C).
Pressure Range: Exceeds 15 psi internal and 1500 psi external.
Operational Life: 50,000 actuations (minimum).
Shelf Life: Excess of 25 years.
Resistant to: Salt spray, sunlight, ozone, weather, fungus, and most acids and lubricating oils.
Agency Recognition: UL & ULC Recognized to UL Std. 50

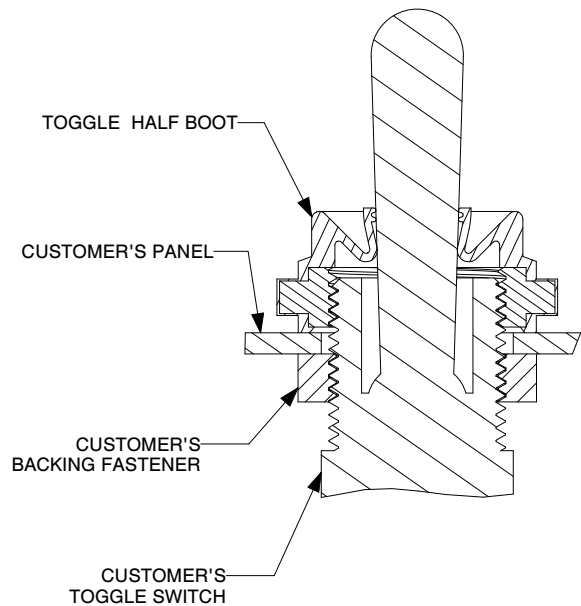
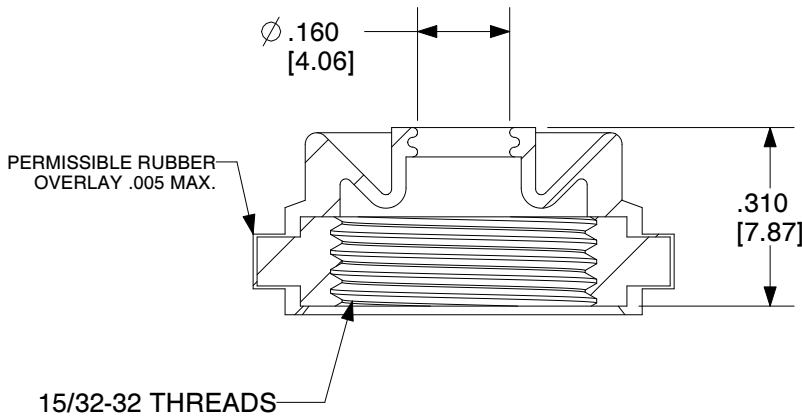
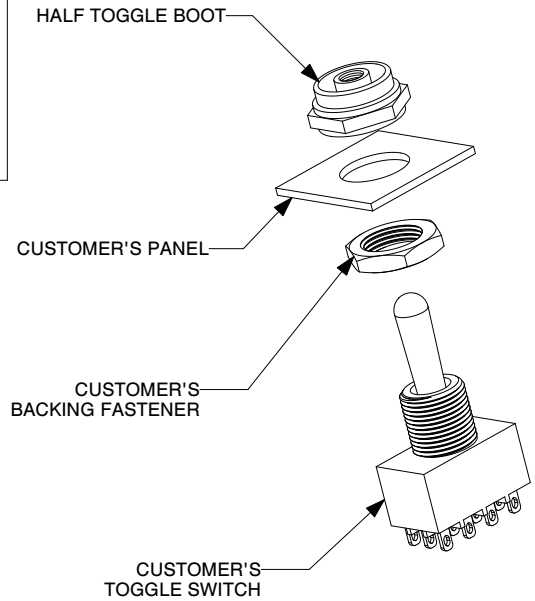
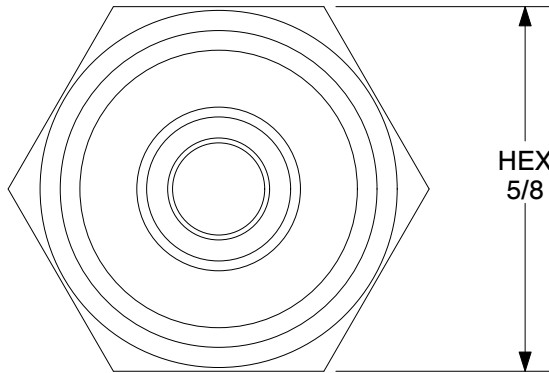

REV.	DESCRIPTION	DATE	
MAXIMUM AND MINIMUM MEASUREMENTS ARE STATED DIRECTLY ON EACH DIMENSION. MAT'L: SILICONE RUBBER PER A-A-59588 CLIII GR25 FINISH: GRAY	TITLE: HALF BOOT, TOGGLE INVERTED BELLOWS APM-HEXSEAL CORPORATION	ENG. DAN LAW	09.26.13
		DWN: DAN LAW	09.26.13
		CHKD KEN F.	10.14.13
	SCALE NTS	DWG_NO	1132/60

THIS DRAWING COVERS PROPRIETARY ITEM AND IS THE PROPERTY OF THE APM-HEXSEAL CORPORATION. THIS DRAWING IS NOT TO BE COPIED OR USED WITHOUT THE WRITTEN APPROVAL OF AN OFFICER OF THE APM-HEXSEAL CORPORATION.